

(19) World Intellectual Property Organization
International Bureau



(43) International Publication Date
30 October 2003 (30.10.2003)

PCT

(10) International Publication Number
WO 03/089890 A1

- (51) International Patent Classification⁷: G01J 3/28, 3/447, 3/51
- (21) International Application Number: PCT/GB03/01630
- (22) International Filing Date: 15 April 2003 (15.04.2003)
- (25) Filing Language: English
- (26) Publication Language: English
- (30) Priority Data: 0208869.8 18 April 2002 (18.04.2002) GB
- (71) Applicant (for all designated States except US): QINETIQ LIMITED [GB/GB]; Registered Office, 85 Buckingham Gate, London SW1E 6PD (GB).
- (72) Inventors; and
- (75) Inventors/Applicants (for US only): HARVEY, Andrew, Robert [GB/GB]; Heriot Watt University, Room 2.05, Department Computing Engineering, Riccarton, Edinburgh EH14 4AS (GB). FLETCHER-HOLMES, David, William [GB/GB]; Heriot Watt University, Room 3.15, Department Computing Engineering, Riccarton, Edinburgh EH14 4AS (GB).
- (74) Agent: DAVIES, P.; IP QinetiQ Formalities, Cody Technology Park, A4 Building, Room G016, Ivelly Road, Farnborough, Hampshire GU14 0LX (GB).
- (81) Designated States (national): AE, AG, AL, AM, AT, AU, AZ, BA, BB, BG, BR, BY, BZ, CA, CH, CN, CO, CR, CU, CZ, DE, DK, DM, DZ, EC, EE, ES, FI, GB, GD, GE, GH, GM, HR, HU, ID, IL, IN, IS, JP, KE, KG, KP, KR, KZ, LC, LK, LR, LS, LT, LU, LV, MA, MD, MG, MK, MN, MW, MX, MZ, NI, NO, NZ, OM, PH, PL, PT, RO, RU, SC, SD, SE, SG, SK, SL, TJ, TM, TN, TR, TT, TZ, UA, UG, US, UZ, VC, VN, YU, ZA, ZM, ZW.
- (84) Designated States (regional): ARIPO patent (GH, GM, KE, LS, MW, MZ, SD, SL, SZ, TZ, UG, ZM, ZW), Eurasian patent (AM, AZ, BY, KG, KZ, MD, RU, TJ, TM), European patent (AT, BE, BG, CH, CY, CZ, DE, DK, EE, ES, FI, FR, GB, GR, HU, IE, IT, LU, MC, NL, PT, RO, SE, SI, SK, TR), OAPI patent (BF, BJ, CF, CG, CI, CM, GA, GN, GQ, GW, ML, MR, NE, SN, TD, TG).
- Declaration under Rule 4.17:**
— of inventorship (Rule 4.17(iv)) for US only

[Continued on next page]

(54) Title: IMAGING SPECTROMETER

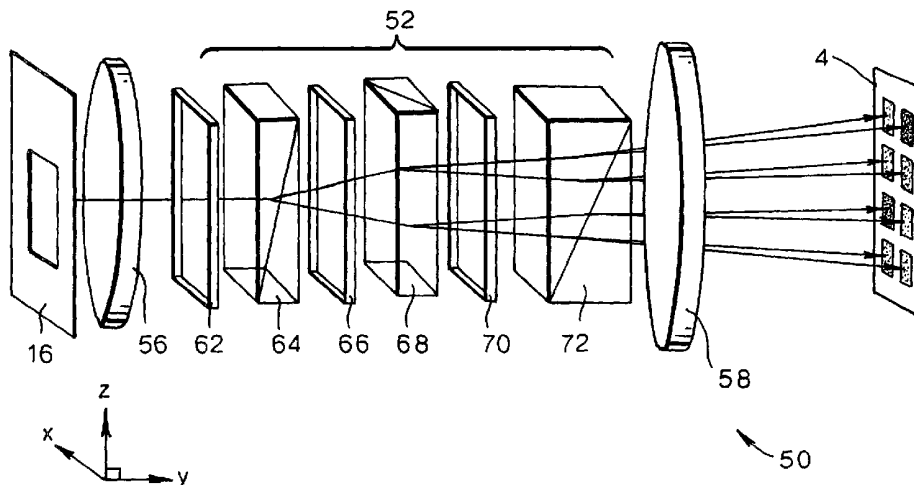

(57) Abstract: An imaging spectrometer (2) is disclosed that comprises imaging means for dividing a received image into two or more spatially separated spectral images and means for detecting each spectral image (4), and is characterised in that the imaging means comprises at least one polarising beam splitter (18, 20, 22; 64, 68, 72). The polarising beam splitter may be a Wollaston prism. In one embodiment of the invention, the imaging means comprises image replication means (12) to produce two or more spatially separated images, and one or more filter elements such as dichroic filters (8) which act to alter the spectral characteristics of one or more of the spatially separated images. In a further embodiment of the invention the imaging means comprises one or more spectral replication means arranged in optical series, each spectral replication means comprising an optical retardation element (62, 66, 70) and a polarising beam splitter (64, 68, 72).



WO 03/089890 A1